

INSTALLATION & CARE INSTRUCTIONS

Duette[®] with Vertiglide[™]

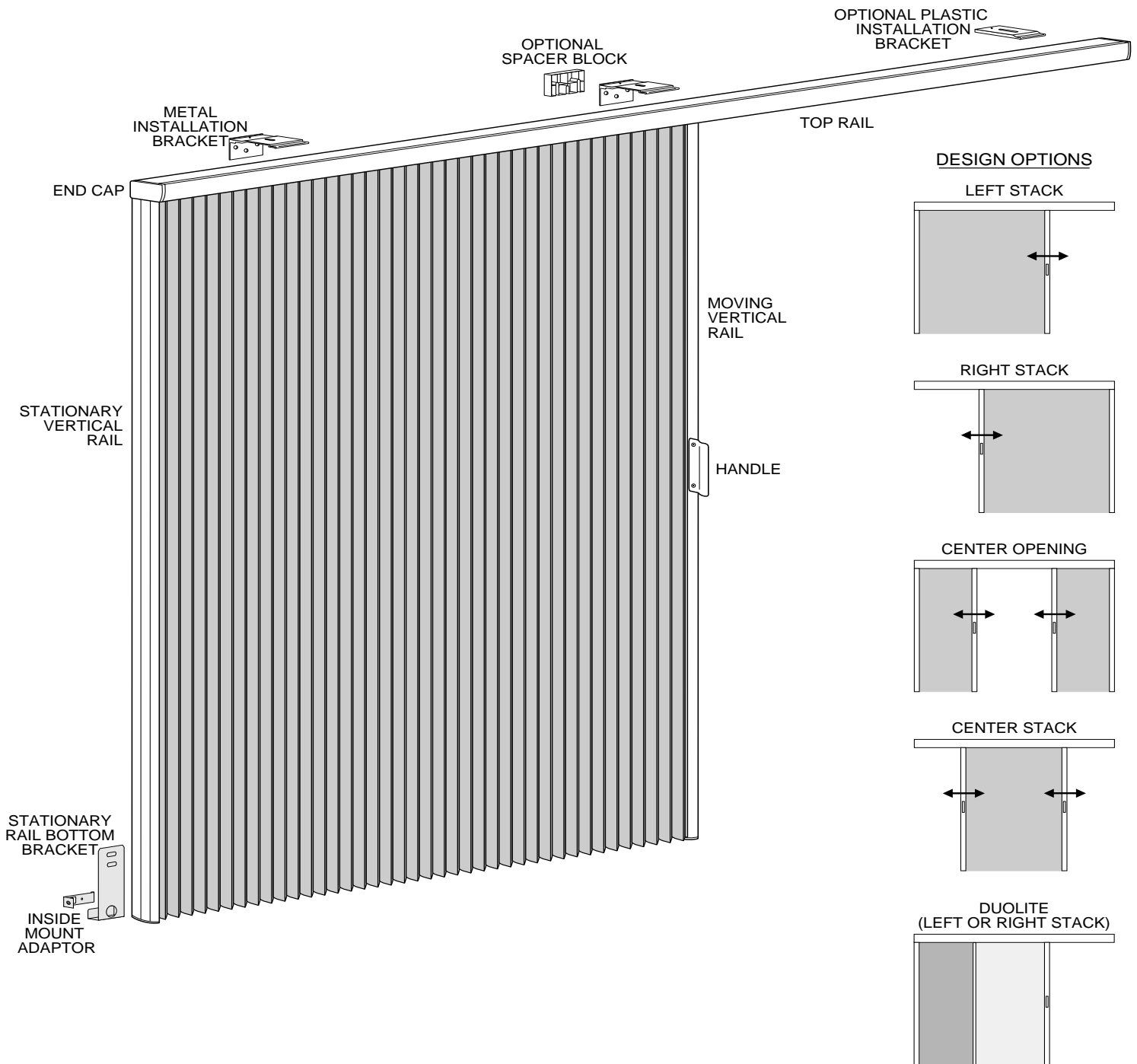

HunterDouglas
window fashions

FIRST THINGS FIRST . . .

Thank you for choosing Duette® window fashions. This unique honeycomb design is state-of-the-art in both form and function. With proper installation and care, your new Duette® with Vertiglide™ shade will provide many years of beauty and performance.

To install your shade, you will need a few basic tools:

- Measuring Tape
- Power Drill and Drill Bits
- Long Flat Blade Screwdriver
- Phillips Screwdriver
- Carpenter's Level

In addition to the tools, you will need a supply of mounting screws to attach the installation brackets. For non-solid surfaces, such as drywall, wall anchors or expansion bolts are required.

Caution: *Be careful not to cut any cords while unpacking the shade.*

Installation brackets are attached either inside or outside the window or door opening. Both metal and plastic brackets are available, but the plastic brackets can be used on inside mounted or ceiling mounted shades only. Spacer blocks can be used with the metal installation brackets to extend the shade out from the mounting surface to clear obstructions. The stationary rail bottom bracket fits into the stationary rail and is attached to the floor or wall to secure the rail. An adaptor allows the bracket to be inside-mounted to the casement. If necessary with outside mounts, an extension bracket can be used to extend the stationary rail bottom bracket away from the mounting surface.

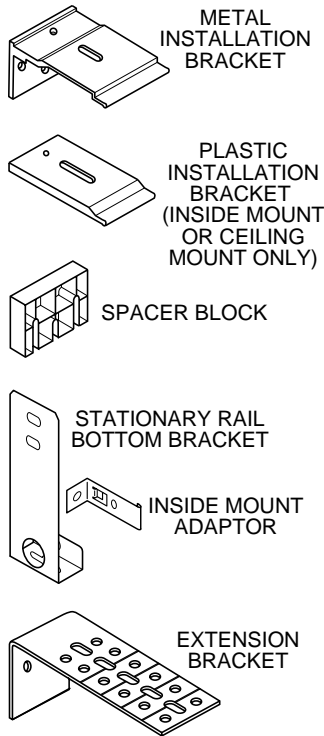

A magnetic strip and steel pull strip may be used on inside mount applications and center opening designs for full closure along the entire height of the moving rail(s). Other

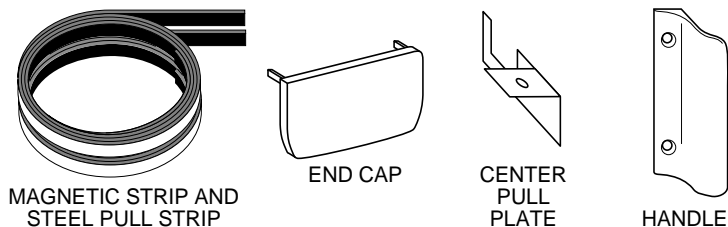

components include top rail end caps for outside mount applications; a center pull plate for center opening designs; and a handle for each moving rail. Before beginning the installation, check to be sure you have all the shade

assembly materials needed for your particular installation. Then, clear a work space at least as large as the shade's outside dimensions and read these instructions all the way through to acquaint yourself with the installation procedures.

There are five options for Duette with Vertiglide shades: *left stack, right stack, center stack, center opening, and Vertiglide™ Duolite®*. The installation procedures for the four designs are similar. Left stack procedures will be shown and installation differences among the other designs will be highlighted.

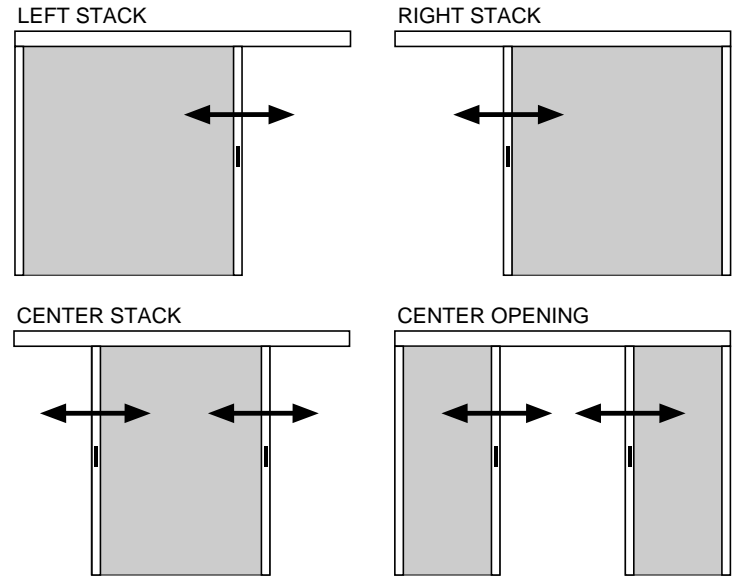

1 ATTACH THE INSTALLATION BRACKETS

BRACKET SPACING

Two installation brackets are positioned on the mounting surface approximately 8" from the ends of the shade, and additional brackets are spaced evenly between the two end brackets. See the following chart for the number of brackets required. Measure and mark all bracket locations.

SHADE WIDTH UP TO 79":	3 BRACKETS
SHADE WIDTH 79" – 127":	4 BRACKETS
SHADE WIDTH 127" – 168":	5 BRACKETS

For *center opening* designs over 168" wide, two top rails are butted together end-to-end. Bracket quantities are calculated separately for each rail, plus one additional installation bracket is included with the shade. This additional bracket is positioned where the two rails meet to align them accurately.

INSIDE MOUNTS

With inside mounts, attach the tops of the installation brackets to a flat horizontal surface at least 1" deep with plastic brackets or 1⁵/₈" deep

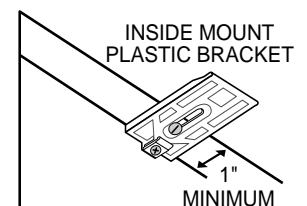

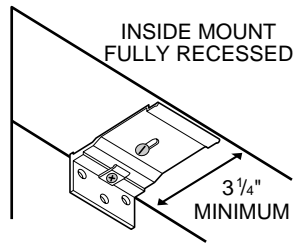
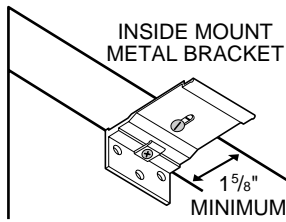

with metal brackets. To fully recess the shade, the opening must be at least 3 1/4" deep with either type of bracket. Additional depth is required if the shade needs to be moved away from the door or window to clear obstructions that protrude more than 5/8" toward the fabric. Installation brackets for ceiling mounted shades are attached the same way as inside mounts.

OUTSIDE MOUNTS

With outside mounts, attach the ends of the installation brackets to a flat vertical surface at least 1 3/8" high. Position the brackets at the locations you marked, with the tops of the brackets at a height equal to the ordered height of the shade plus the desired floor clearance (3/4" is standard). Align the tops perfectly horizontal using a carpenter's level, and mount the brackets with the appropriate fasteners (three per bracket).

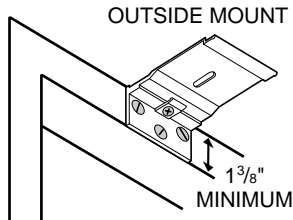

Spacer blocks can be used on outside mounts to project the installation brackets away from the mounting surface so that the shade can clear obstructions which would interfere with its normal operation (protrusions of 5/8" or more). Up to three spacer blocks can be used between the mounting surface and the end of the installation bracket. Each spacer block adds 1/2" of clearance. The solid side of the spacer block must always face the mounting surface.

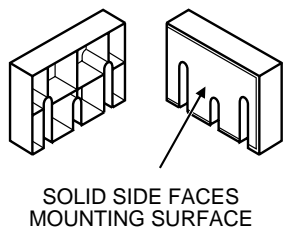
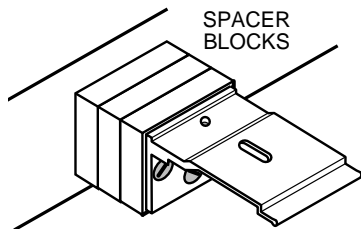

2 ASSEMBLE THE SHADE

COMPONENT ARRANGEMENT

Refer to the following illustrations and arrange the shade components on the floor with the front (colored) side of the fabric panel and the front of the top rail (the wider curved side) both facing up. **Caution:** Do not put tension on the cord when arranging shade components.

With a *left stack* design, position the moving rail bracket (the bracket with the two bearings) next to the left end of the top rail. With a *right stack* design, position the moving rail bracket next to the right end.

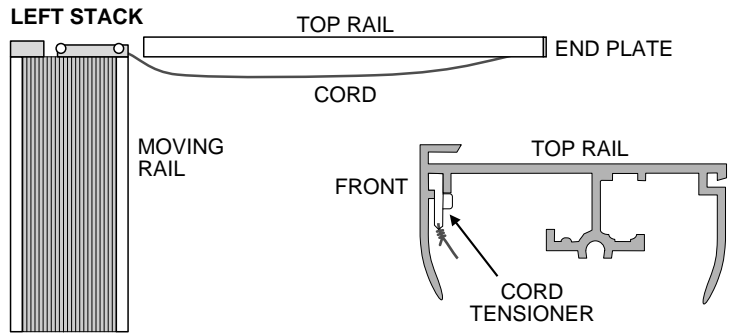

A cord tensioner may already be inserted into the front groove at one end of the top rail, with an end plate attached to that end of the rail. If so, move the cord tensioner to within 2" of the end plate to avoid putting tension on the cord when the components are arranged. If the end plate is not attached and the cord tensioner not inserted, do not install them until after you assemble the fabric and vertical rails onto the top rail. For illustration purposes only, the left stack design is shown above with the cord tensioner and end plate installed, and the right stack design is shown below with these components not installed.

RIGHT STACK

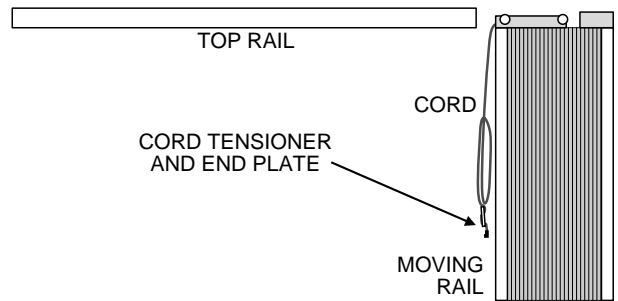

With a *center stack* design, there are two moving rails, each with a moving rail bracket. If an end plate is attached to one end of the top rail, position the fabric and moving rails next to the other end. If no end plate is attached, the fabric and rails can be installed onto either end of the top rail.

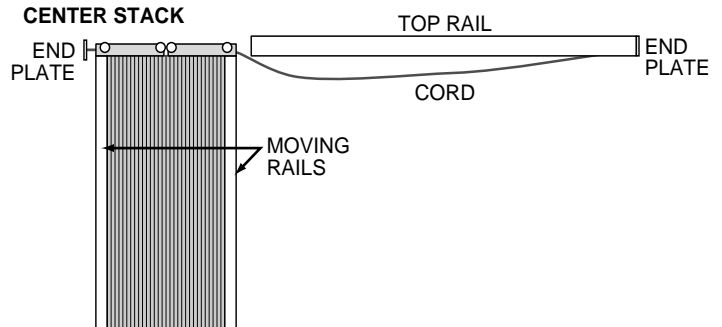

The *center opening* design has two fabric panels, each with one moving rail. Position the moving rail brackets at opposite ends of the top rail.

With all designs, it is important to remember *not* to put tension on the cord while the shade is being assembled. The cord is connected to a cord tensioning spring which can be damaged by excessive cord tension. After the shade is

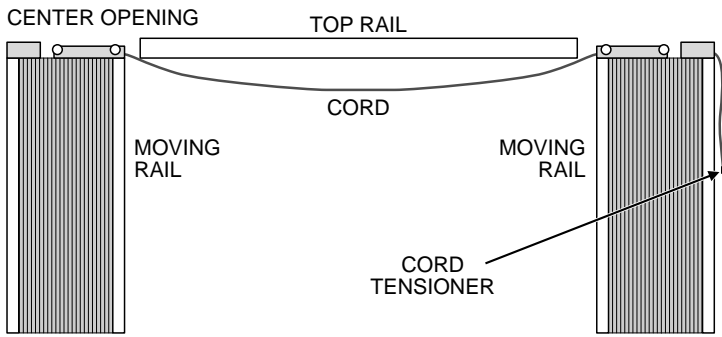

mounted, the cord tensioner is adjusted to put spring tension on the cord, holding it taut under the top rail.

STATIONARY RAIL BOTTOM BRACKET

Check that the stationary rail bottom bracket is installed into the bottom of the single stationary rail on *left stack* and *right stack* designs, and into the bottom of both stationary rails on *center opening* designs. The bracket should be inserted almost all the way into the rail, with the short side toward the rear. No bracket is used on *center stack* designs because both vertical rails are moving rails.

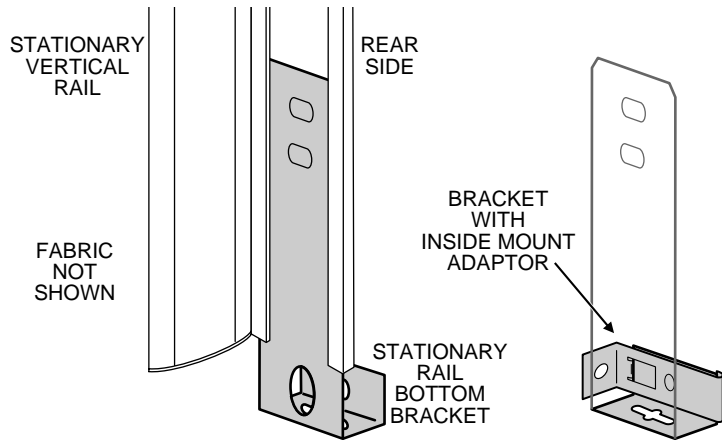

The stationary rail bottom bracket may have an *inside mount adaptor* attached to it. The adaptor allows the bracket to be attached to the casement on inside mount applications, rather than screwed into the floor through the bracket's bottom hole.

MOVING RAIL AND FABRIC INSTALLATION

With the fabric stack(s) next to the correct end(s) of the head-rail, you are ready to install the moving rail(s) and fabric onto the headrail. The bearings on the moving rail bracket are installed into the rear track in the top rail and the fabric carrier bearings are installed into the front track. The rail cross-section shown at right illustrates the two tracks.

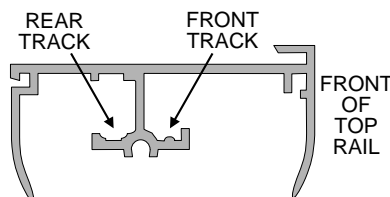

Slide the bearings on the moving rail bracket into the rear track first. Then slide the fabric carrier bearings onto the front track. Be careful not to allow the cord to become tangled in the moving rail bracket or fabric carriers.

MOVING RAIL INSTALLATION

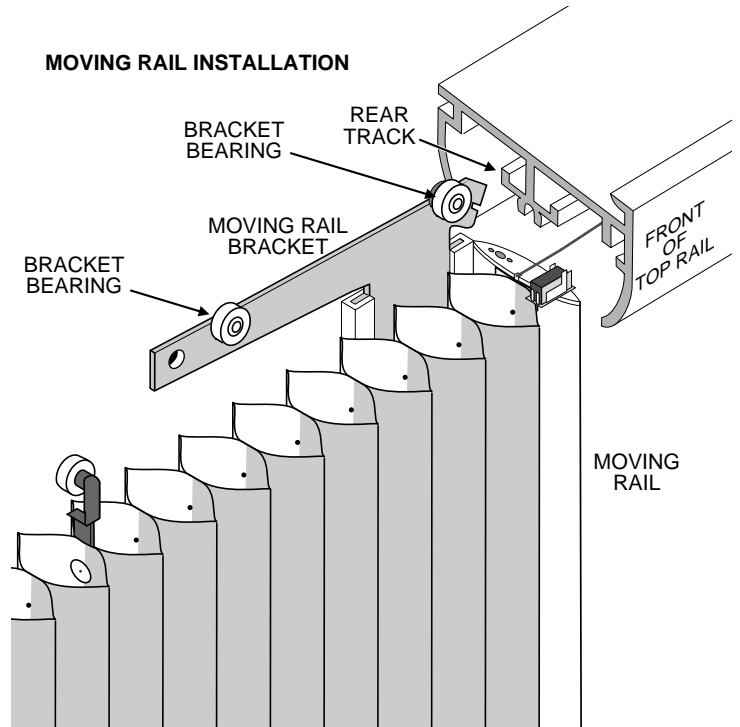

FABRIC INSTALLATION

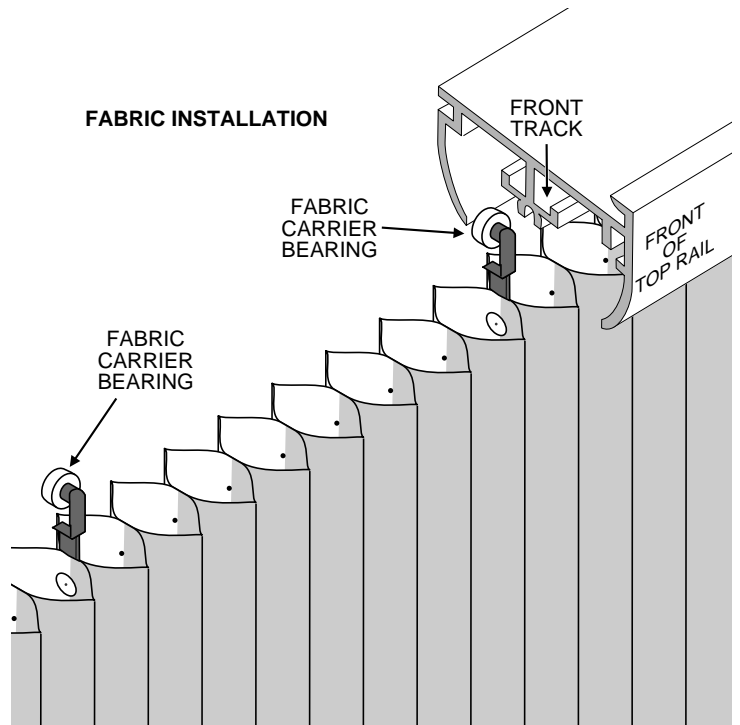

The above illustrations show moving rail and fabric installation for a *left stack* design. With a *right stack* design, the moving rail and fabric would be installed at the right end of the headrail. With a *center opening* design, installation could occur at either end of the headrail; a second moving rail bracket would be installed into the rear track after all the fabric carriers have been installed into the front track. With a *center stack* design, a moving rail and fabric panel is installed into each end of the headrail.

After the fabric and moving rail(s) have been installed, the ends of the headrail are enclosed by attaching the stationary rail(s) and/or the end plate(s), as described next.

STATIONARY RAIL ATTACHMENT

The stationary rail is attached to the top rail with a screw through the stationary rail bracket. The screw (supplied with the shade) fits into a channel between the front and rear tracks, as shown. Again, the illustration is for a *left stack* design. With a *right stack* design, the stationary rail would be attached to the other end of the top rail.

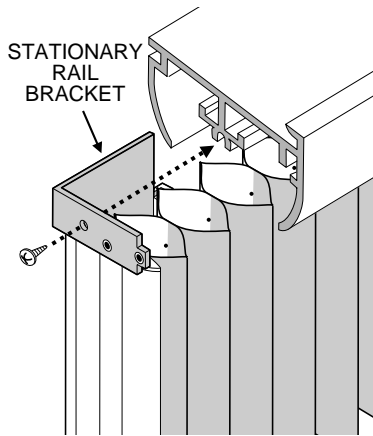

With a *center stack* design, no stationary rails are used.

With a *center opening* design, stationary rails are attached to both ends of the top rail. Be sure to insert the cord tensioner into the front groove inside the top rail before attaching the stationary rail bracket to that end of the rail. (See the end plate illustration below.)

END PLATE ATTACHMENT

If necessary, install the cord tensioner and end plate at this time. First double-check to be sure the cord is not tangled. Then insert the cord tensioner into the front groove inside the top rail, and orient the end plate with the tab to the front and the notches on the top, as shown. Screw the end plate to the center channel using the end plate screw provided, being careful not to pinch the cord between the rail and the end plate.

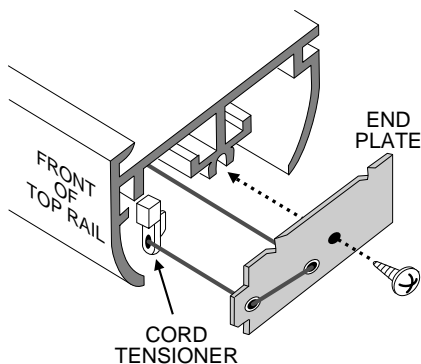

The illustration shows the end plate being attached to the top rail of a *left stack* design. With a *right stack* design, the cord tensioner and end plate would be installed on the left end of the rail.

With *center stack* designs, end plates are attached to both ends of the top rail. The second end plate on *center stack* designs has the opposite end of the cord attached to it, and is attached to the top rail in the same way.

Center opening designs do not use end plates, since stationary rails are attached to both ends of the top rail.

CENTER PULL PLATE INSTALLATION

Center opening designs require a center pull plate to serve as a stop for the two moving rails. Attach the center pull plate inside the top rail. A hole for the

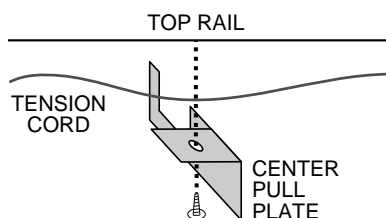

screw is pre-drilled $\frac{1}{2}$ " to the left of where the two moving rails will meet when the shade is closed. Capture the tension cord in the open part of the center pull plate, as shown in the illustration.

3 MOUNT AND ADJUST THE SHADE ASSEMBLY

MOUNTING THE SHADE

Carefully lift the assembled shade. Place the top of the top rail against the bottom front of the installation brackets. Push the top rail straight back so that the front lip slides over the front of the brackets and the back lip fits over the tab on the brackets. Center the top rail and then tighten the tab screws to secure the shade.

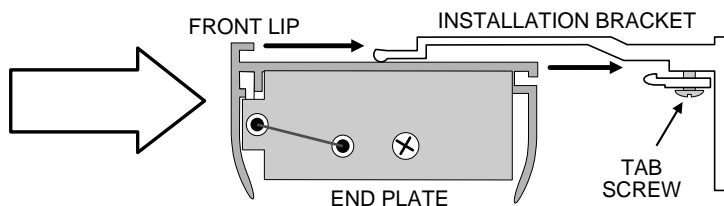

STATIONARY RAIL BOTTOM BRACKET

Attach the stationary rail bottom bracket to the floor, wall, or casement. Before attaching the bracket, use a carpenter's level to make sure the stationary rail is exactly vertical when viewed both from the front and the side. Alternatively, you may adjust the rail to match the alignment of jambs or mullions.

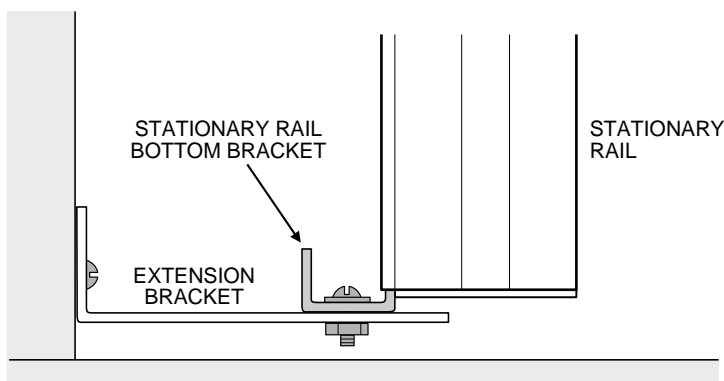

With a wall-mounted bottom bracket on outside mount applications, use an extension bracket if it is necessary to move the stationary rail away from the wall, as shown above.

The bracket on inside mount applications may be attached to the casement (the inside frame of the opening) using the inside mount adaptor. Simply attach the bracket to the casement with a screw through the adaptor hole.

Center opening designs use two stationary rail bottom brackets, one for each stationary rail. *Center stack* designs do not use stationary rail bottom brackets, since both vertical rails are moving rails.

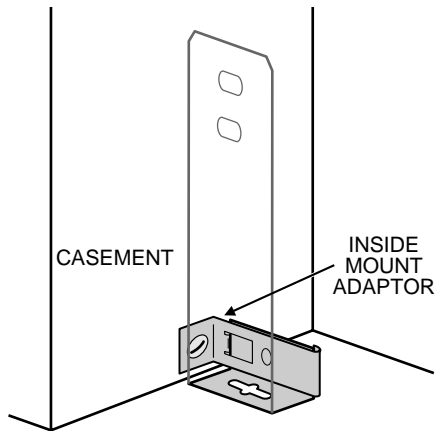

CORD TENSIONER ADJUSTMENT

The cord, which runs under the top rail and through the fabric, must be set at the proper tension. This adjustment is performed with the shade open all the way, so that the fabric is stacked.

To adjust the cord's tension, reach two fingers under the front of the top rail and hold the cord tensioner perpendicular between them. Slide the cord tensioner away from the end plate until you first feel spring resistance, and then slide it approximately 6" further away from the end plate. This will make the cord taut under the center of the top rail. (With *center opening* designs, you will be moving the cord tensioner away from a stationary rail bracket, not an end plate.)

Open and close the shade to check its operation. The moving rail should slide easily and hold its position when released. *Decrease* cord tension if the moving rail moves too stiffly, or *increase* tension if the rail does not hold its position.

MOVING RAIL ADJUSTMENT

If necessary, adjust the angle of the moving rail using the adjusting screw on the moving rail bracket. Tighten or loosen the screw to straighten the rail or to align it with the jamb. Tightening the screw adjusts the moving rail away from the fabric. Loosening the screw adjusts the moving rail towards the fabric. If further adjustment is needed to adjust the rail towards the fabric, the moving rail bracket needs to be removed and the rear bracket bearing moved to the #2 hole. Unmount the shade for inside mount designs. After the rear bearing is

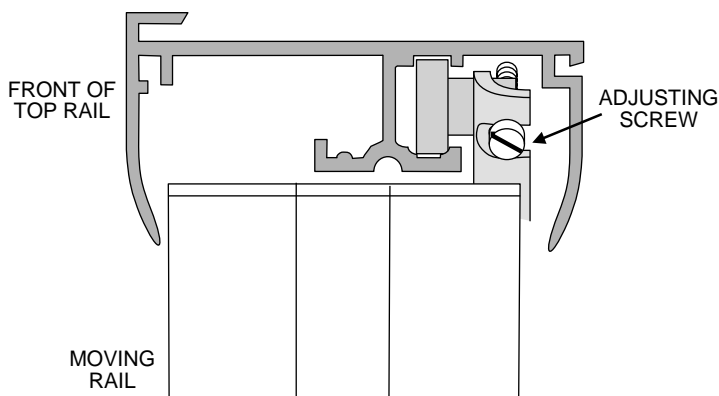

moved to the #2 hole, refer to the "Moving Rail and Fabric Installation" section to reinstall the moving rail and continue from there.

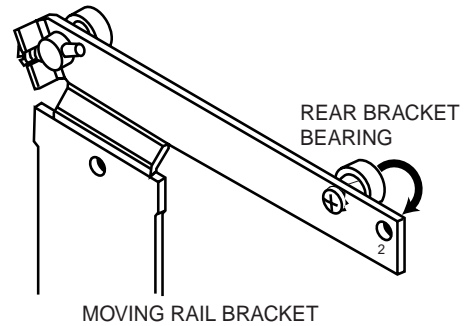

FINAL ASSEMBLY

Handle holes are pre-drilled into each moving rail. Attach the handle(s) using the screws provided.

Install end caps on outside-mounted units. Simply insert the end cap protrusions into the appropriate grooves on the top rail and push or tap the end cap until it is flush with the rail.

Install a magnetic strip and steel pull strip on inside-mounted units and all *center opening* designs. Remove the adhesive backing and fit the strips into the center groove on the moving rail(s) and on the jamb. *Center stack* designs require two sets of strips. With *center opening* designs, the magnetic strip fits into the center groove on one moving rail, and the steel pull strip fits into the groove on the other moving rail.

CARE AND CLEANING

Because the Duette® fabric is anti-static, it requires very little cleaning. A light sweep with your vacuum cleaner brush attachment is all that is needed to keep it dust-free. For a more thorough cleaning, the entire shade assembly may be gently wiped with a soft damp cloth using lukewarm water. Take special care when handling opaque fabrics to avoid creasing, and do not immerse in water. Professional ultrasonic cleaning is another option except for shades made with opaque fabrics. Only mild cleaning solutions should be used.



HunterDouglas

window fashions

hunterdouglas.com

Where Great Rooms Begin.

© 1988, 2002 Hunter Douglas Inc. ®Registered trademark of Hunter Douglas Inc.
™Trademark of Hunter Douglas Inc. Patented in the U.S. and foreign countries.
U.S. and foreign patents pending.



PCN 5101620000

rev.3/02

10M-3/02